

NPR

Delivering profit to you



MAIN SPECIFICATIONS

Class	NPR				
Model	NPR85H	NPR85K	NPR85H	NPR85K	NPR85F
Rear Tire	Dual	Dual	Dual	Dual	Dual
G.V.W. [Kg]	6,500	6,500	6,500	6,500	7,500
Type	Cab Chassis/ Flat Cargo	Cab Chassis/ Flat Cargo	Crew Cab Chassis/ Flat Cargo	Crew Cab Chassis/ Flat Cargo	Dump Body
Seating Capacity	3	3	7	5	3

ENGINE

Model	4JJ1-TCC	4JJ1-TCC	4JJ1-TCC	4JJ1-TCC	4JJ1-TC
Type	Direct Injection DOHC, Diesel				
No. of cylinders	4	4	4	4	4
Displacement [cc]	2,999	2,999	2,999	2,999	2,999
Max. Output [PS/rpm]	130 / 2,800	130 / 2,800	130 / 2,800	130 / 2,800	130 / 2,800
Max. Torque [kg·m/rpm]	34.0 / 1,600	34.0 / 1,600	34.0 / 1,600	34.0 / 1,600	34.0 / 1,600
Starter	24V - 4.0kW	24V - 4.0kW	24V - 4.0kW	24V - 4.0kW	24V - 4.0kW

MASS (kg)

Cab Chassis / Vehicle Mass	2397 / 2852	2434 / 2944	2560 / 2905	2652 / 3097	3287
----------------------------	-------------	-------------	-------------	-------------	------

CHASSIS

Clutch	Type	Dry Single Plate				
	Size [Mm]	300	300	300	300	300
Transmission	Type	MY-5T 5Speed	MY-5T 5Speed	MY-5T 5Speed	MY-5T 5Speed	MY-6S 6Speed
	Diameter [mm]	292	292	292	292	320
Final Gear	Gear Ratio	6.142	6.142	6.142	6.142	6.142
	Type	Oil Brake with Power Assist				
Brake	Parking	Center Brake				
	Type	Power Assist				
Axle	Front	F031	F031	F031	F031	F031
	Rear	R050	R050	R050	R050	R066
Suspension		FR MultiLeaf & RR MutliLeaf		FR TaperLeaf & RR MutliLeaf	FR MultiLeaf & RR MutliLeaf	
Frame		850mm Straight	850mm Straight	FR 820mm & RR 750mm	850mm Straight	850mm Straight
Tire	Front & Rear	215/75R17.5 (OPT 7.5R-16-12)	215/75R17.5 (OPT 7.5R-16-12)	215/75R17.5 (OPT 7.5R-16-12)	215/75R17.5 (OPT 7.5R-16-12)	215/75R17.5 (OPT 7.5R-16-12)
	Disc Wheel	17.5X6.00-127 (OPT 6.00GSX16-127)	17.5X6.00-127 (OPT 6.00GSX16-127)	17.5X6.00-127 (OPT 6.00GSX16-127)	17.5X6.00-127 (OPT 6.00GSX16-127)	17.5X6.00-127 (OPT 6.00GSX16-127)
Fuel Tank Capacity Liter		100L [OPT 200L]	100L [OPT 200L]	100L	100L	100L

NPR					
NPR81H	NPR81K	NPR75F	NPR75K	NPR75K	NPR75L
Dual	Dual	Dual	Dual	Dual	Dual
6,500	6,500	7,500	7,500	7,500	7,500
Cab chassis/ Flat Cargo	Cab chassis /Flat Cargo	Cab chassis / Dump	Cab chassis / Flat Cargo	Cab chassis	Cab chassis
3	3	3	3	3	3

4HL1-TCN	4HL1-TCN	4HK1-TCN	4HK1-TCN	4HK1-TCN	4HK1-TCN
Direct Injection, OHC, Diesel					
4	4	4	4	4	4
4,778	4,778	5,193	5,193	5,193	5,193
130 / 2,600	130 / 2,600	150 / 2,600	150 / 2,600	150 / 2,600	150 / 2,600
38 / 1,600	38 / 1,600	41.0 / 1,500	41.0 / 1,500	41.0 / 1,500	41.0 / 1,500
24V - 4.0kW	24V - 4.0kW	24V - 4.0kW	24V - 4.0kW	24V - 4.0kW	24V - 4.0kW

2630 / 3055	2685 / 3170	2555 / 3485	2725 / 3210	2740	2785
-------------	-------------	-------------	-------------	------	------

Dry Single Plate				Fluid Coupling	Dry single plate
300	300	325	325	-	325
MY-6S 6Speed	MY-6S 6Speed	MY-6S 6Speed	MY-6S 6Speed	MY-6S 6Speed NEES	MY-6S 6Speed
292	292	320	320	320	320
4.777	4.777	4.777	4.556	4.556	4.556
Oil Brake with Power Assist					
Center Brake					
Power Assist					
F031	F031	F031	F031	F031	F031
R050	R050	R066	R066	R066	R066
FR MultiLeaf & RR MutliLeaf					
850mm Straight	850mm Straight	850mm Straight	850mm Straight	850mm Straight	850mm Straight
215/75R17.5 (OPT 7.5R-16-12)	215/75R17.5 (OPT 7.5R-16-12)	215/75R17.5 (OPT 7.5R-16-12)	215/75R17.5 (OPT 7.5R-16-12)	215/75R17.5 (OPT 7.5R-16-12)	215/75R17.5 (OPT 7.5R-16-12)
17.5X6.00-127 (OPT 6.00GSX16-127)	17.5X6.00-127 (OPT 6.00GSX16-127)	17.5X6.00-127 (OPT 6.00GSX16-127)	17.5X6.00-127 (OPT 6.00GSX16-127)	17.5X6.00-127 (OPT 6.00GSX16-127)	17.5X6.00-127 (OPT 6.00GSX16-127)
100L [OPT 200L]	100L [OPT 200L]	100L	100L [OPT 200L]	100L [OPT 200L]	100L [OPT 200L]

NLR | NMR | NQR | NPS

Delivering
profit to you



MAIN SPECIFICATIONS

Class	NLR		NMR	
Model	NLR77E	NMR85E	NMR85H	NMR85H
Rear Tire	Single	Dual	Dual	Dual
G.V.W. [Kg]	4,550	5,200 [OPT 5,500]	5,200 [OPT 5,500]	5,200 [OPT 5,500]
Type	Cab chassis / Flat Cargo	Cab chassis / Dump Body	Cab chassis / Flat Cargo	Crew Cab chassis / Flat Cargo
Seating Capacity	3	3	3	6

ENGINE

Model	4JH1-TC	4JJ1-TC	4JJ1-TC	4JJ1-TC
Type	Direct injection, OHC, diesel	Direct Injection, DOHC		
No. of cylinders	4	4	4	4
Displacement [cc]	2,999	2,999	2,999	2,999
Max. Output [PS/rpm]	106/3,200	130 / 2,800	130 / 2,800	130 / 2,800
Max. Torque [kg m/rpm]	23.5/1,400	34.0 / 1,600	34.0 / 1,600	34.0 / 1,600
Starter	12V-2.0kW	24V – 4.0KW	24V – 4.0KW	24V – 4.0KW

MASS (kg)

Cab Chassis / Vehicle Mass	1755 / 2065	2070 / 2625	2090 / 2450	2365 / 2675

CHASSIS

Clutch	Type	Dry Single Plate			
	Size [mm]	250	300	300	300
Transmission	Type	MSB-5S 5Speed	MY-5T 5Speed	MY-5T 5Speed	MY-5T 5Speed
	Diameter [mm]	244	292	292	292
Final gear	Gear ratio	5.125	5.375 / 5.571	5.375	5.375
	Type	Oil Brake with VAC	Oil Brake with VAC 5.2t [OPT Power Assist 5.5t]		
Brake	Parking	Center Brake			
	Type	Power Assist			
Axle	Front	F029	F029	F029	F029
	Rear	R036	R050/R045	R050	R050
Suspension		FR MultiLeaf & RR MultiLeaf	FR TaperLeaf / FR Multi leaf RR MultiLeaf	FR TaperLeaf & RR MultiLeaf	
Frame		FR 740mm & RR 700mm	FR 740mm & RR 700mm	FR 740mm & RR 700mm	FR 740mm & RR 700mm
Tire	Front & Rear	205/85R16	195/85R16	195/85R16	205/85R16
Disc wheel	Front & Rear	16X5.5J-85	16X5.5J-116.5	16X5.5J-116.5	16X5.5J-116.5
Fuel tank capacity	liter	75L	75L	100L	75L

NQR					NPS
NQR75K	NQR75L	NQR75M	NQR90L	NQR90M	NPS75H
Dual	Dual	Dual	Dual	Dual	Dual
8,500	8,500	8,500	9,500	9,500	6,000
Cab chassis	Cab chassis	Cab chassis	Cab chassis	Cab chassis	Cab chassis
3	3	3	3	3	3

4HK1-TCN	4HK1-TCN	4HK1-TCN	4HK1-TC	4HK1-TC	4HK1-TCN
Direct injection, OHC, diesel					
4	4	4	4	4	4
5,193	5,193	5,193	5,193	5,193	5,193
150 / 2,600	150 / 2,600	150 / 2,600	150 / 2,600	150 / 2,600	150 / 2,600
41.0 / 1,500	41.0 / 1,500	41.0 / 1,500	41.0 / 1,500	41.0 / 1,500	41.0 / 1,500
24V – 4.0KW	24V – 4.0KW	24V – 4.0KW	24V – 4.0KW	24V – 4.0KW	24V – 4.0KW

2715	2785	2805	2875	2945	2925
------	------	------	------	------	------

Dry Single Plate					
325	325	325	325	325	325
MY-6S 6Speed	MY-6S 6Speed	MY-6S 6Speed	MY-6S 6Speed	MY-6S 6Speed	MY-5T 5Speed
320	320	320	320	320	320
4.777	4.777	5.125	5.125	5.125	5.125
Oil Brake with Power Assist			Full Air Brake		Oil Brake HBB
Center Brake			Wheel Park Brake		Center Brake
Power Assist					
F033	F033	F033	F031	F031	Fd028
R066	R066	R066	R066	R066	R066
FR MultiLeaf & RR MultiLeaf					
850mm Straight	850mm Straight	850mm Straight	850mm Straight	850mm Straight	850mm Straight
215/75R17.5 (OPT 7.5R-16-14)	215/75R17.5 (OPT 7.5R-16-14)	215/75R17.5 (OPT 7.5R-16-14)	215/75R17.5	215/75R17.5	7.5R-16-10
17.5X6.00-127 (OPT 6.00GSX16-127)	17.5X6.00-127 (OPT 6.00GSX16-127)	17.5X6.00-127 (OPT 6.00GSX16-127)	17.5X6.00-127	17.5X6.00-127	6.00GSX16-127
100L [OPT 200L]	100L [OPT 200L]	100L [OPT 200L]	200L	200L	100L

DIMENSIONS

Unit:mm

MODEL	NLR77E	NLR77E	NMR85E	NMR85E	NMR85H	NMR85H	NMR85H	NMR85H	NPR85H	NPR85H	NPR85K	NPR85K	NPR85H	NPR85H	NPR85K	NPR85K
REAR TIRE	Single	Single	Dual	Dual	Dual	Dual	Dual	Dual	Dual	Dual	Dual	Dual	Dual	Dual	Dual	Dual
TYPE	Cab chassis	Flat cargo	Cab chassis	Dump	Cab chassis	Flat cargo	Crew Cab chassis	Crew Cab Flat cargo	Cab Chassis	Flat cargo	Cab Chassis	Flat cargo	Crew Cab Chassis	Crew Cab Flat cargo	Crew Cab Chassis	Crew Cab Flat cargo
OAL	4730	4805	4730	4770	6020	6105	6020	6105	5985	6069	6635	6744	6100	6185	6635	6744
OW	1815	1890	1855	1815	1815	1890	1815	1890	2120	2120	2120	2120	2040	2170	2120	2120
AW	1475	1475	1475	1475	1475	1475	1475	1475	1680	1680	1680	1680	1680	1680	1680	1680
CW	1395	1395	1425	1240	1425	1425	1425	1425	1650	1650	1650	1650	1525	1525	1650	1650
BW	1645	1645	1855	1850	1855	1855	1865	1865	2120	2120	2120	2120	1990	1990	2120	2120
FOH	1110	1110	1110	1110	1110	1110	1110	1110	1110	1110	1110	1110	1110	1110	1110	1110
WB	2475	2475	2475	2475	3345	3345	3345	3345	3365	3365	3815	3815	3395	3395	3815	3815
ROH (Frame end)	1145	1220	1145	1185	1565	1650	1565	1650	1510	1594	1710	1819	1595	1680	1710	1819
CA	2022	2022	2022	2022	2892	2892	1781	1781	2792	2792	3242	3242	1831	1831	2251	2251
CE	3167	3242	3167	3207	4457	4542	3346	3431	4302	4386	4952	5061	3426	3511	3961	4070
OH	2165	2165	2160	2160	2160	2160	2270	2270	2290	2285	2290	2285	2255	2255	2310	2305
FR Axle to cab end	453	453	453	453	453	453	1564	1564	573	573	573	573	1564	1564	1564	1564

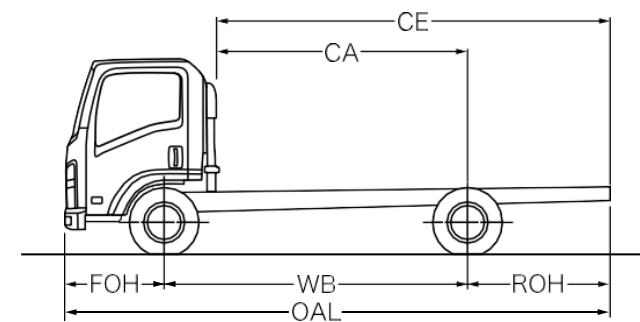
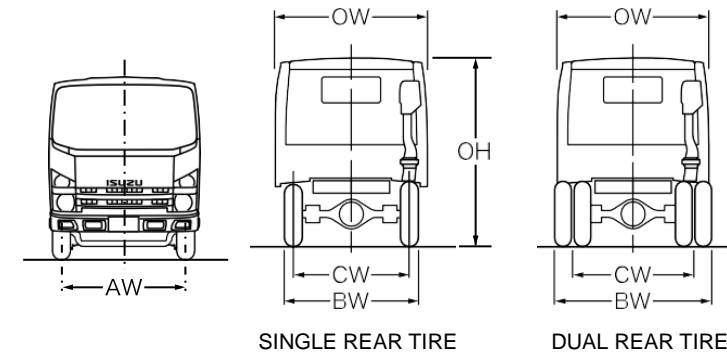

NL / NM / NP / NQ



The photo doesn't reflect the actual dimensions of all the models

Unit:mm

MODEL	NPR85F (7.5t)	NPR81H	NPR81H	NPR81K	NPR81K	NPR75F	NPR75F	NPR75K	NPR75K	NPR75L	NQR75K	NQR75L	NQR75M	NQR90L	NQR90M	NPS75H
REAR TIRE	Dual	Dual	Dual	Dual	Dual	Dual	Dual	Dual	Dual	Dual	Dual	Dual	Dual	Dual	Dual	Dual
TYPE	Dump body	Cab chassis	Flat cargo	Cab chassis	Flat cargo	Cab chassis	Dump	Cab chassis	Flat cargo	Cab chassis	Cab chassis	Cab chassis	Cab chassis	Cab chassis	Cab chassis	Cab chassis
OAL	5115	5985	6140	6635	6820	5385	5115	6635	6790	7355	6635	7355	7815	7355	7870	6015
OW	2140	2120	2170	2120	2170	2120	2140	2120	2170	2120	2120	2120	2120	2120	2120	2120
AW	1680	1680	1680	1680	1680	1680	1680	1680	1680	1680	1680	1680	1680	1680	1680	1675
CW	1650	1650	1650	1650	1650	1650	1650	1650	1650	1650	1650	1650	1650	1650	1650	1650
BW	2120	2120	2120	2120	2120	2120	2120	2120	2120	2120	2120	2120	2120	2120	2120	2120
FOH	1110	1110	1110	1110	1110	1110	1110	1110	1110	1110	1110	1110	1110	1110	1110	1080
WB	2765	3365	3365	3815	3815	2765	2765	3815	3815	4175	3815	4175	4475	4175	4475	3395
ROH (Frame end)	1240	1510	1665	1710	1895	1510	1240	1710	1865	2070	1710	2070	2230	2070	2285	1540
CA	2228	2792	2792	3242	3242	2192	2192	3242	3242	3602	3242	3602	3902	3602	3902	2792
CE	3468	4302	4457	4952	5137	3702	3432	4952	5107	5672	4952	5672	6132	5672	6187	4332
OH	2295	2265	2265	2265	2265	2265	2265	2265	2265	2265	2255	2255	2255	2245	2245	2455
FR Axle to cab end	537	573	573	573	573	573	573	573	573	573	573	573	573	573	573	603

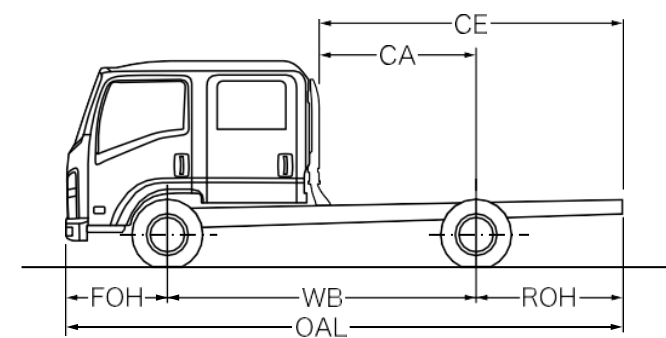
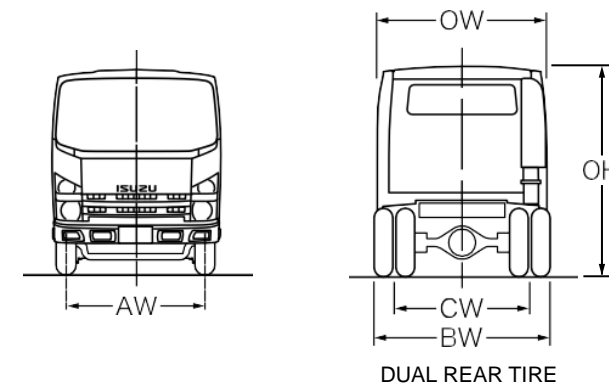

NM / NP Crew cab



The photo doesn't reflect the actual dimensions of all the models